

Harness for the Jay[®] J3 Back

Installation Guide

1. Remove the J3 Back cover and any foam Spine Align position components from the aluminum shell to avoid damage during installation.

NOTE: Identify the location of the foam Spine Align components for proper attachment after the harness installation is complete.

2. Identify the 8 laser-cut starter holes (A,B) (four on each side) to be used for attaching the harness to the shell.
3. Use a 1/4" (6.5cm) drill bit and drill out the 8 starter holes.

NOTE: Once complete, use a file to smooth any sharp edges and ensure that no metal shards will be caught in the cover.

4. Attach the "Goal Post" harness guides (C) to the top-rear of the aluminum shell. Tighten fasteners according to the torque specifications listed.
5. Attach all four harness points to the shell (D). Tighten nuts according to the torque specifications listed.
6. Reinsert Spine Align components to their original position and reattach cover to the aluminum back shell.
7. Insert both harness straps (E) into the top slot of the "Goal Post" harness guides.
8. Have the user seated back in the chair and adjust the straps to the user as needed.

NOTE: The bottom straps should be positioned at a 45° angle relative to the pelvis.

⚠ WARNING

The ComforFit Anterior Trunk Supports are **NOT** suitable for use as a transportation restraint. This restraint does not comply with SAE Standard J2249. When using a wheelchair as a motor vehicle seat, always use a restraint that complies with SAE J2249.

For more information visit the Ride Safe web site at <http://www.travelsafer.org>.

⚠ WARNING: CHOKING HAZARD

Make sure the rider does not slide down in the wheelchair seat. If this occurs, the rider may suffer chest compression or suffocate due to pressure from the supports.

The supports must be snug but must not be so tight that they interfere with breathing. You should be able to slide your open hand, flat, between the belt and the rider.

NEVER use positioning supports as a patient restraint or on a rider who is comotose or agitated.

Failure to heed these warnings can result in severe injury or death.

If you have further questions on installation or adjustment, please contact A.R.T. Group customer service at 1-800-944-8246.

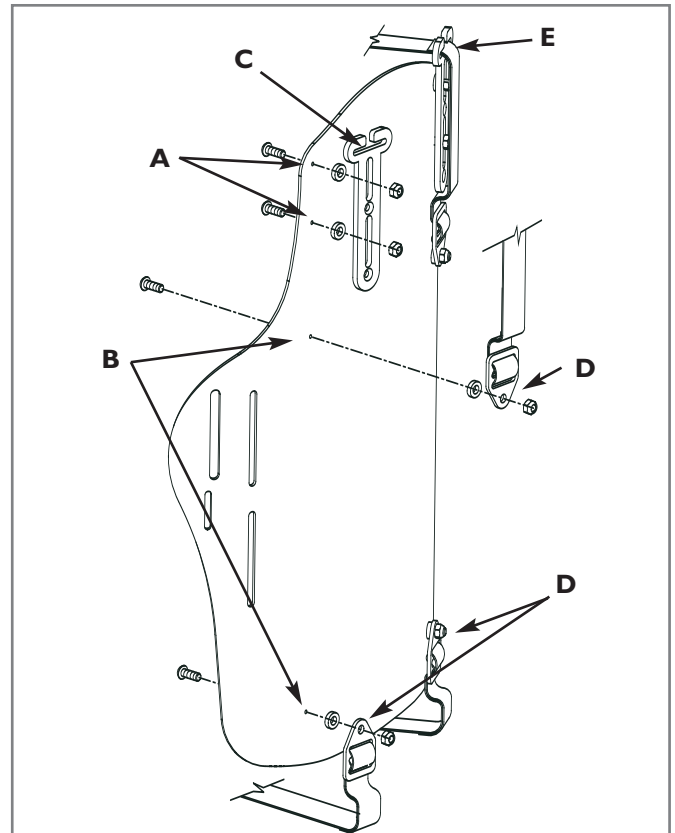

Tools Needed

- 4mm Hex Key (supplied with J3 Back)
- 10mm Combo Wrench (Supplied with J3 Back)

Maintenance and Torque Specifications

Sunrise recommends that all fasteners be checked monthly for wear, such as loose bolts or broken components. Loose fasteners should be retightened according to the installation instructions.

All fasteners should be tightened to 2.3 N-m (20 in-lbs).

Check harness monthly for frayed straps, ripped seams or other indications of excessive wear or damage. Discontinue use if damage is found. Chest straps should be replaced at the first indication of damage and/or excessive wear.

If a broken or loose component is identified, immediately discontinue use and contact your authorized Sunrise Medical supplier for replacement.